

Signature™ Windows series

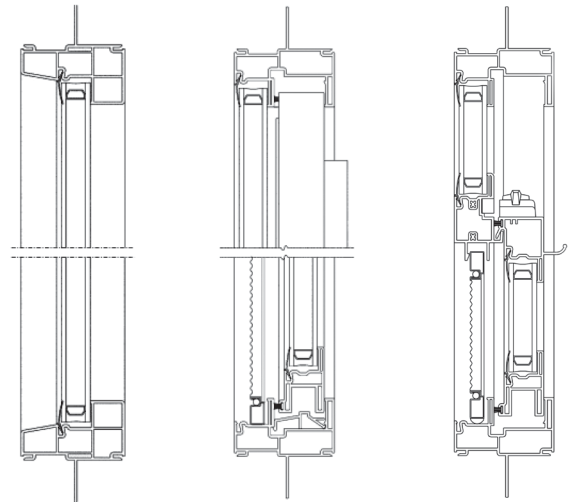

Picture Single-Slide Single-Hung

Versatile design, contemporary look

The Signature Series combines a versatile look with high performance. Whether new construction or replacement, the common components result in easier fabrication & faster lead-times. Available in White, Clay, or Black with White interior.



White

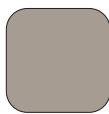

Clay



Black/White



- 2-11/16" frame depth provides strength performance.
- Multi-chambered frame with weep channels for efficient drainage.
- SunShield® Vinyl offers superior weather resistance with no painting.
- Interlocking sash for better air & water infiltration resistance.
- 1-3/8" nail-fin set back accommodates most exterior trim.
- Automated welding on sash & frame.
- Insulated glass is 3/4" OA with Double Strength glass & Argon standard.
- Limited lifetime warranty.

Performance Ranges

Structural
NAFS: Up to LC-PG40

Thermal
U Factor: Down to .26

Acoustical
STC: Up to 34db